

TEAMTEC INCINERATORS

Market leaders since 1972 - More than 6 000 units sold

Type GS500C

One of the most effective marine incinerators on the market today – primarily for sludge. Fully automatic sludge burning eliminates the need for attendance. Batch feeding of solid waste.

*Solid waste and sludge can be burned simultaneously.
Capacity: Max. 730 000 kcal/h (850 kW)*



- High temperature incinerator
- Automatic control
- High capacity
- Sturdy construction
- Easy installation
- Disassembled retrofit-version*
- Extremely low diesel consumption
- Simple reliable operation
- No filters /strainers in sludge system
- Low maintenance cost
- PLC controller minimizes fuel consumption and maximizes capacity utilization

* small components - no welding.



MED approved



ISO 9001 CERTIFIED COMPANY

TeamTec GS500C – Optional equipment

(list not complete)

- Sludge and diesel oil tanks
- Diesel oil booster pump
- Sludge tank level indicator in operator display
- Flue gas stack components
- Sluice for continuous feeding of solid waste
- Mechanical solid waste feeder
- Version for solid waste only (separate brochure)
- Corner mounted against bulkheads possible
- Skid mounted
- Containerized incinerating plants
- Project-versions

Main dimensions

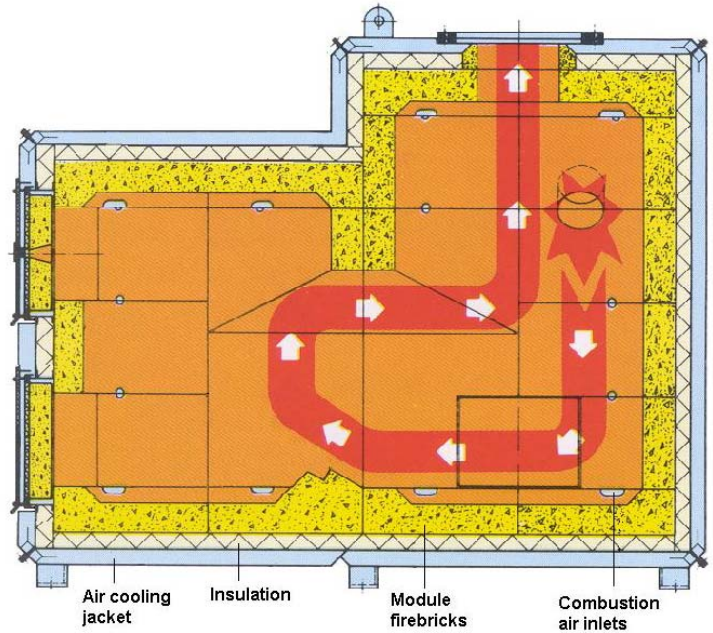
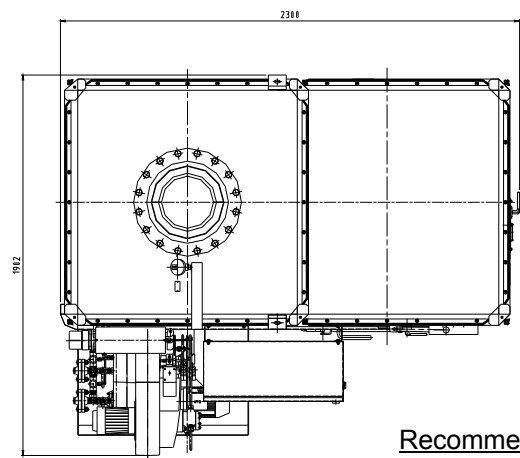
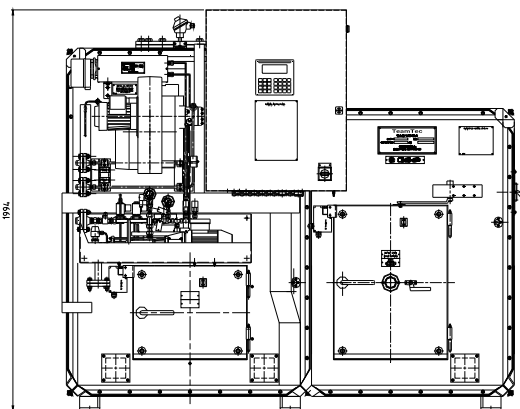

Technical data:

Power supply:	440V/60Hz or 380V/50Hz (other options available)
Capacity:	max. 730 000 kcal/h (850 kW)
Corresponding to:	max. 95 l/h sludge oil (IMO defined sludge)
Solid waste:	400 l/load
Temperature in	
Combustion chamber:	max. 1 200 °C
Surface temperature:	15 °C above ambient temp.
Flue gas temperature:	350 °C
Flue gas back pressure:	max. 150 mm W.C.
Negative pressure in	
Combustion chamber:	from 10 to 35 mm W.C.
Max. rated el. power:	approx. 27 kW

Total weight:	approx. 4 450 kg
Dimensions (L x W x H mm):	2 300 x 1 902 x 1 994
Footprint (L x W mm):	2 000 x 1 000

Certified by all major classification societies incl. USCG according to IMO MEPC 76(40).

Recommended Ship's Incinerator Installation

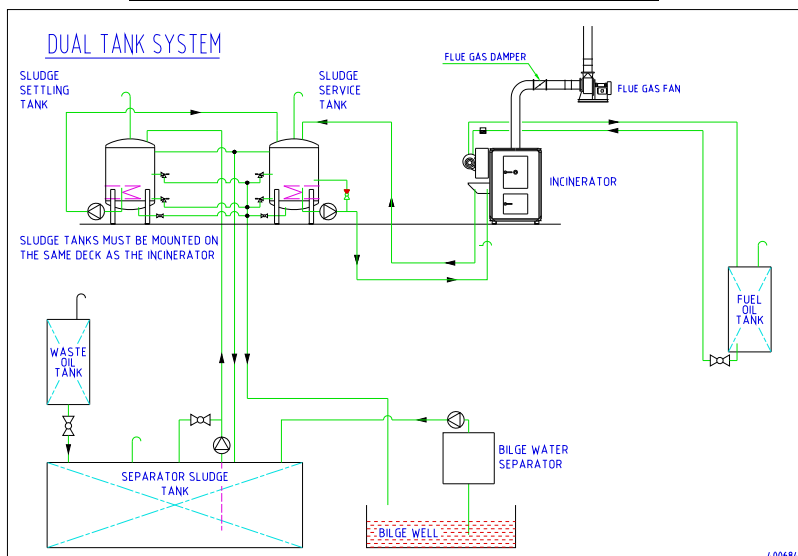

TeamTec AS

P.O. Box 203, N-4902 Tvedestrand, Norway

Tel. +47 37 19 98 00. Fax +47 37 19 98 90. Web: www.teamtec.no. E-mail: office@teamtec.no